

CATEGORY	DESCRIPTION	P/N #
CONNECTOR	0.50mm FPC CONNECTOR SWING ACTUATOR TYPE, H=2.0mm	FC023R-XX010-092S

FC023R-XX010-092S
See Table 1

PROPOSAL ONLY

REV.	ECN NO	DESCRIPTION	REVISED	DATE
A01		New Release	Luguan	2009.08.13

- SPECIFICATION**
- CURRENT RATING : 0.5 Amp MAX.
 - DIELECTRIC WITHSTANDING VOLTAGE : AC 500V.
 - INSULATION RESISTANCE: 50MΩ MIN.
 - OPERATING TEMPERATURE : -20° C TO +85° C.

Table 1:
Pin Q'TY & Dimension

Q'TY	Dimension				Q'TY	Dimension			
	A	B	C	D		A	B	C	D
04	6.4	1.5	2.6	3.5	33	20.9	16.0	17.1	18.0
05	6.9	2.0	3.1	4.0	34	21.4	16.5	17.6	18.5
06	7.4	2.5	3.6	4.5	35	21.9	17.0	18.1	19.0
07	7.9	3.0	4.1	5.0	36	22.4	17.5	18.6	19.5
08	8.4	3.5	4.6	5.5	37	22.9	18.0	19.1	20.0
09	8.9	4.0	5.1	6.0	38	23.4	18.5	19.6	20.5
10	9.4	4.5	5.6	6.5	39	23.9	19.0	20.1	21.0
11	9.9	5.0	6.1	7.0	40	24.4	19.5	20.6	21.5
12	10.4	5.5	6.6	7.5	41	24.9	20.0	21.1	22.0
13	10.9	6.0	7.1	8.0	42	25.4	20.5	21.6	22.5
14	11.4	6.5	7.6	8.5	43	25.9	21.0	22.1	23.0
15	11.9	7.0	8.1	9.0	44	26.4	21.5	22.6	23.5
16	12.4	7.5	8.6	9.5	45	26.9	22.0	23.1	24.0
17	12.9	8.0	9.1	10.0	46	27.4	22.5	23.6	24.5
18	13.4	8.5	9.6	10.5	47	27.9	23.0	24.1	25.0
19	13.9	9.0	10.1	11.0	48	28.4	23.5	24.6	25.5
20	14.4	9.5	10.6	11.5	49	28.9	24.0	25.1	26.0
21	14.9	10.0	11.1	12.0	50	29.4	24.5	25.6	26.5
22	15.4	10.5	11.6	12.5	51	29.9	25.0	26.1	27.0
23	15.9	11.0	12.1	13.0	52	30.4	25.5	26.6	27.5
24	16.4	11.5	12.6	13.5	53	30.9	26.0	27.1	28.0
25	16.9	12.0	13.1	14.0	54	31.4	26.5	27.6	28.5
26	17.4	12.5	13.6	14.5	55	31.9	27.0	28.1	29.0
27	17.9	13.0	14.1	15.0	56	32.4	27.5	28.6	29.5
28	18.4	13.5	14.6	15.5	57	32.9	28.0	29.1	30.0
29	18.9	14.0	15.1	16.0	58	33.4	28.5	29.6	30.5
30	19.4	14.5	15.6	16.5	59	33.9	29.0	30.1	31.0
31	19.9	15.0	16.1	17.0	60	34.4	29.5	30.6	31.5
32	20.4	15.5	16.6	17.5					

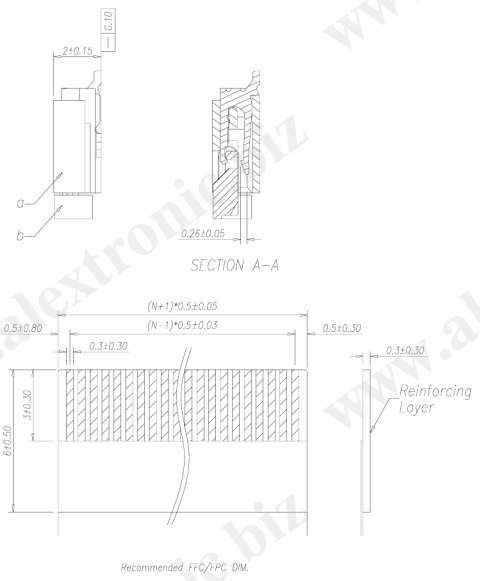
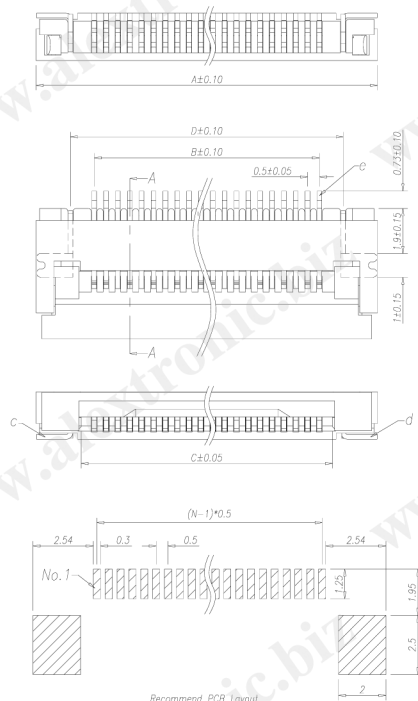

NO.	PART NAME	MATERIAL	PLATING & COLOR	Remark
e	Terminal	XX Phosphor Bronze, T=0.2mm	Matte Tin Plating	
d	R-Peg	1 Brass, T=0.2mm	Matte Tin Plating	
c	L-Peg	1 Brass, T=0.2mm	Matte Tin Plating	
b	Cover	1 Thermoplastic UL94V-0	Black	
a	Housing	1 Thermoplastic UL94V-0	White	

UNLESS OTHERWISE SPECIFIED TOLERANCES

DECIMALS: X : ±0.5 X.X : ±0.3 X.XX : ±0.2

ANGLES: X : ±2° X.X : ±1°

SCALE: free UNIT: mm DWG. NO: WJ-061-651

SIZE: A3 PAGE: 1 OF 1 REV: A01

APPROVED BY: WYX CHECKED BY: Pengjie PREPARED BY: luguan

CUSTOMER COPY

See Table 1